

HANDRAIL TO COLUMN INSTALLATION INSTRUCTIONS

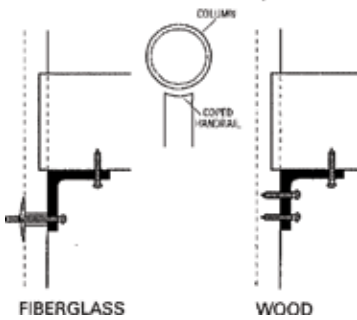

ROUND FIBERGLASS OR WOOD COLUMN

1. Mark the desired height of the rail on the column where there rail is to be attached. **NOTE: Local building codes may dictate the rail height for your particular installation. Be sure to check with your building code official to determine the proper handrail height.**
2. Temporarily hold the handrail in place. Use a carpenters pencil to scribe the curvature of the column onto the top of the handrail. Use a coping saw to cut the curvature into the end of the handrail.
3. With the coped end of the rail held in place, mark and accurately cut the rail to length.
4. A rust resistant corner brace (i.e. Stanley 1 ½" zinc plated corner brace) will be mounted to the handrail with rust resistant screws and to the column with toggle bolts (for fiberglass) or rust resistant screws (for wood columns). Mark the column at the bottom of the handrail. It may be necessary to sand a small area on the column to provide a flat mounting surface for the corner brace.
5. Temporarily hold the corner bracket in place where the bottom of the handrail will be and mark the holes in the corner brace on the column. Pre-drill pilot holes in the column for toggle bolts or rust resistant screws and attach brace to column.
6. Set the handrail in place and attach the corner brace to the bottom of the rail using rust resistant wood screws that are at least 1 ½" long.
7. Apply paintable silicone sealant to the joint between the column and handrail.

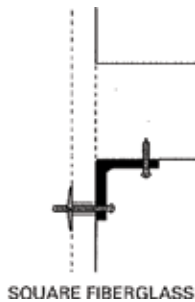

SQUARE FIBERGLASS COLUMN

1. Measure the handrail to the desired length and accurately cut to length.
2. Mark the desired height of the rail on the column face where the rail is to be attached. **NOTE: Local building codes may dictate the rail height for your particular installation. Be sure to check with your building code official to determine the proper handrail height.**
3. A rust resistant corner brace (i.e. Stanley 1 ½" zinc plated corner brace) will be mounted to the column and the bottom of the handrail with rust resistant screws. Mark the column at the bottom of the handrail.
4. Temporarily hold a rust resistant corner bracket in place where the bottom of the handrail will be and mark the holes in the corner brace on the column. Pre-drill holes in the column large enough to receive a toggle bolt.
5. Attach the rust resistant corner brace to the square fiberglass column by using toggle bolts with rust resistant machine screws.
6. Set the handrail in place and attach the rust resistant corner brace to the bottom of the rail using rust resistant wood screws that are at least 1 ½" long.
7. Apply paintable silicone sealant to the joint between the column and handrail.